

||||| **DC1000A** Precision DC Bias Current Source **Voltech**



||||| A universal solution for magnetics testing under real world conditions
Precision, flexibility, simplicity

A single DC bias solution for all your magnetics testing needs

Power electronics circuits frequently require inductive components to operate at high levels of DC current. The DC1000A from Voltech is used to apply bias current to transformers and chokes for impedance testing under working conditions, integrating seamlessly with any LCR meter and with Voltech's own AT-Series (AT5600, AT3600 and ATi) testers.

The DC1000A provides an unbeatable combination of precision, flexibility, and simplicity. It allows measurements with up to ten times the accuracy of existing solutions. Because it can work with any LCR meter, and features a simple yet robust interconnect design, it can be quickly interchanged across multiple test stations, providing a single, flexible solution for all your DC bias needs.

When used in combination with Voltech's own AT-Series testers, the DC1000A provides even more benefits. It can be controlled directly from AT test programs, facilitating fast, comprehensive single-station testing of any magnetic component.

The DC1000A features a patented design that eliminates the need to purchase specific DC bias supplies for use with particular LCR meters, and dramatically increases test performance. Unique sensing and control circuitry reduces and quantifies error currents, producing more accurate results; it allows open and short compensation to eliminate stray effects; it means that the DC1000A requires no special connection to the LCR meter; and it allows parallel connection of multiple DC1000A current sources for testing at high bias currents.

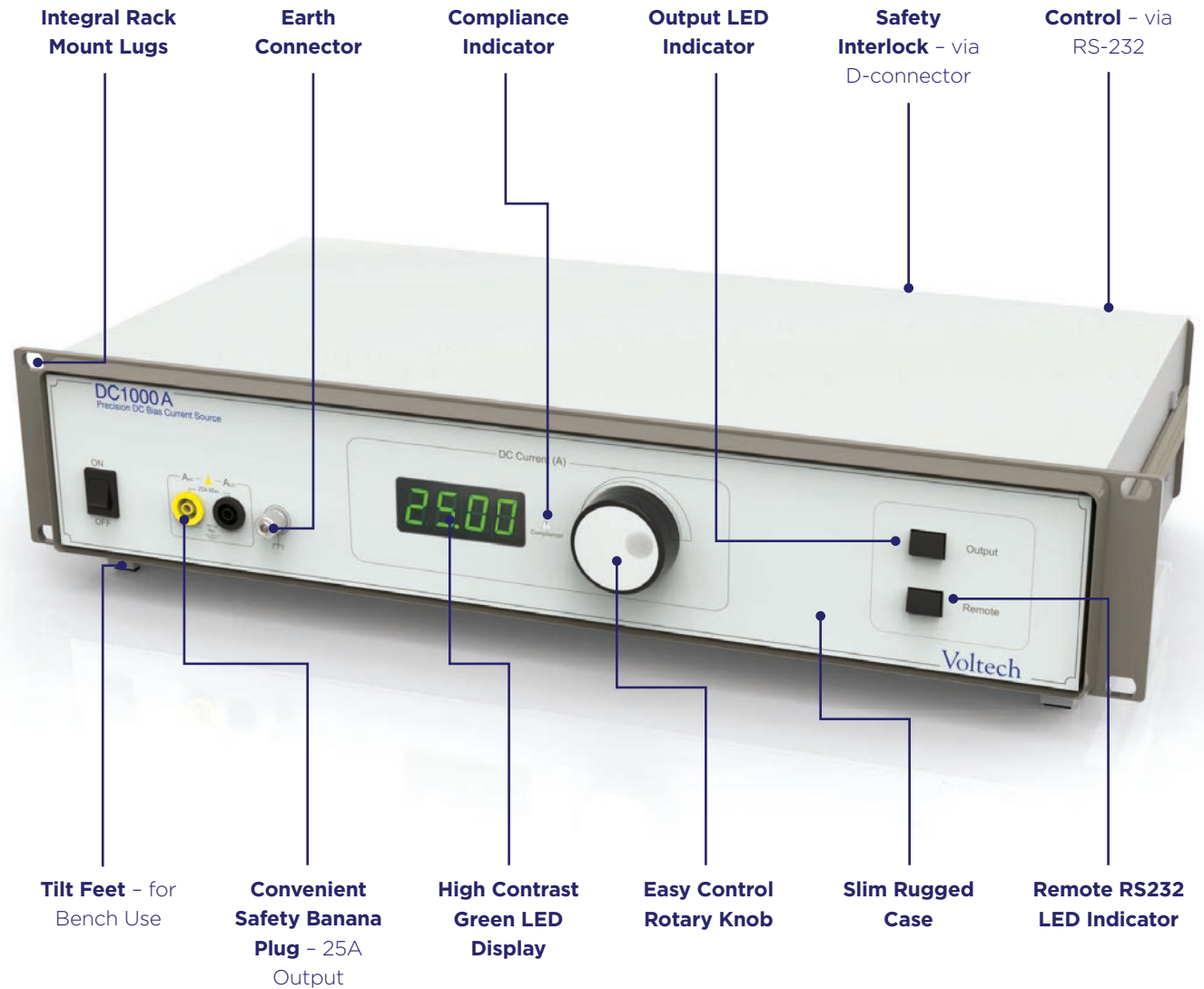

PRECISION

The DC1000A provides 10x the precision of our previous DC bias solution, enabling LCR measurements to an accuracy of 0.01 μ A/mV. It's ideally suited not only for achieving high levels of product quality via manufacturing test, but also for accurate characterization of product specifications – such as core saturation behavior – in the design phase.

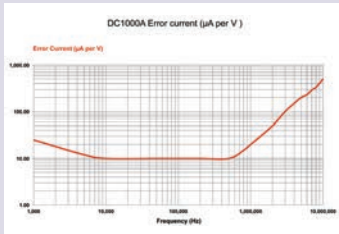

FLEXIBILITY

The DC1000A is the only DC bias current source to be designed for use with any LCR meter, including those from Agilent, Wayne Kerr and Chroma. So you can retrofit DC bias testing capabilities to your existing test infrastructure, and choose freely when you need to upgrade your instruments. Our simple interconnect system allows you to move the DC1000A quickly and easily between test stations, for flexibility and cost-effective operation in the production environment.



SIMPLICITY

The DC1000A is designed to be simple to add to an existing magnetics testing station, with patented sensing and control circuitry so that it requires no special connection to the associated LCR meter. When combined with a choice of manual or remote programming modes, this means you can get a DC bias testing process up and running in minutes.

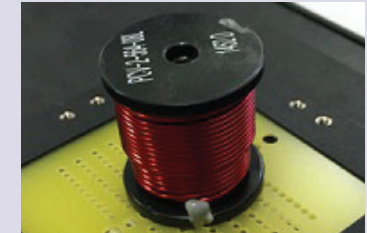

DC1000A at a glance

- Universal: works with any LCR meter
- Integrates closely with Voltech AT-Series testers
- 10x the accuracy of previous solutions: 0.01 μ A/mV
- Precision: \pm 0.5% of current reading \pm 25mA
- Up to 25A from a single source
- Up to 500A with multiple units
- 20Hz – 3MHz dynamic range
- Flexible: simple connections, can be moved between test stations in minutes
- Fully protected
- Compact, lightweight
- Controlled via front panel or RS232 link
- Safety interlock
- Rack mount or bench-standing



A universal DC bias solution

The DC1000A is optimized for use with Voltech's AT-Series magnetics testers: but unlike competing products, it can also be used with any third-party LCR meter. This gives you ultimate flexibility: whether you're building a magnetics test capability from scratch, or retro-fitting DC bias capabilities to an existing test infrastructure.

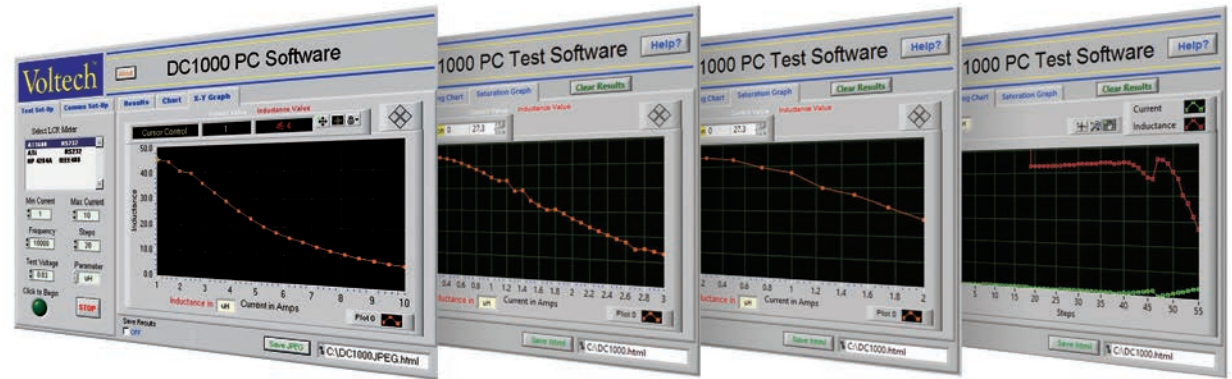
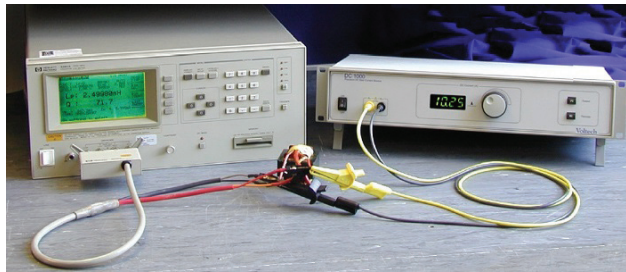

USE WITH ANY LCR METER

The DC1000A is the only DC bias current source to be designed for use with any LCR meter that has a bias compensation system or bias connection, including those from Agilent, Wayne Kerr and Chroma. Its high output impedance, achieved through patented sensing and control circuitry (see page 6), makes it easy to connect and operate, allowing you to get up and running in minutes.

The DC1000A can be programmed manually or remotely, and we include PC Sweep software for design and quality checks.

DESIGN AND CHARACTERIZATION

The DC1000A is much more than a production test tool. We include free PC-based software that helps you to validate and optimize product specifications by plotting the magnetic saturation characteristics of your designs. You can see the true margin between the core's operating point and its theoretical saturation, giving you, and your customers, complete confidence that your products will perform as specified.

SEAMLESS INTEGRATION WITH AT-SERIES TESTERS

The DC1000A works seamlessly with Voltech's AT Series transformer testers - the industry's most deployed automatic magnetics testers. Delivering ten times the throughput of manual test strategies, AT Series testers allow you to perform any combination of tests on any magnetic component via a single test station.

AT Series test programs offer you seamless control of both the tester and the DC1000A DC bias unit. You can get tests set up quickly and easily, and make changes and refinements in minutes. The newest member of the AT Series, the AT5600, includes Audit and Diagnostic Test facilities, allowing you to improve quality and troubleshoot problems, all within the same automated test system.



Innovative technology: proven reputation

The DC1000A features unique patented technology that permits its use with any LCR meter, decreases error currents by a factor of 10, and allows you to interconnect multiple units to achieve extremely high bias currents.

ENABLING HIGH-CURRENT TESTING

It is often vital to test inductive components not just at their expected operating point, but in the presence of their maximum rated DC current: in the case of devices such as power supply smoothing chokes, this current may be substantial.

The exceptionally high output impedance of the DC1000A allows you to use up to 20 units in parallel, to generate up to 500A of DC bias. Set-up is extremely simple - all you need to do is link the units' RS232 and safety interlock interfaces in a "daisy-chain", and connect the outputs using standard test leads. No special fixturing or interconnection is required: everything you need to hook up multiple current sources is included with the unit. The first DC1000A in the daisy chain becomes the "master" unit, allowing control of the full chain either via its front panel, by an interconnected AT56/AT36/ATi, or by simple commands via the RS232 interface. Compensation set-up and testing itself is as simple as using a single current source.

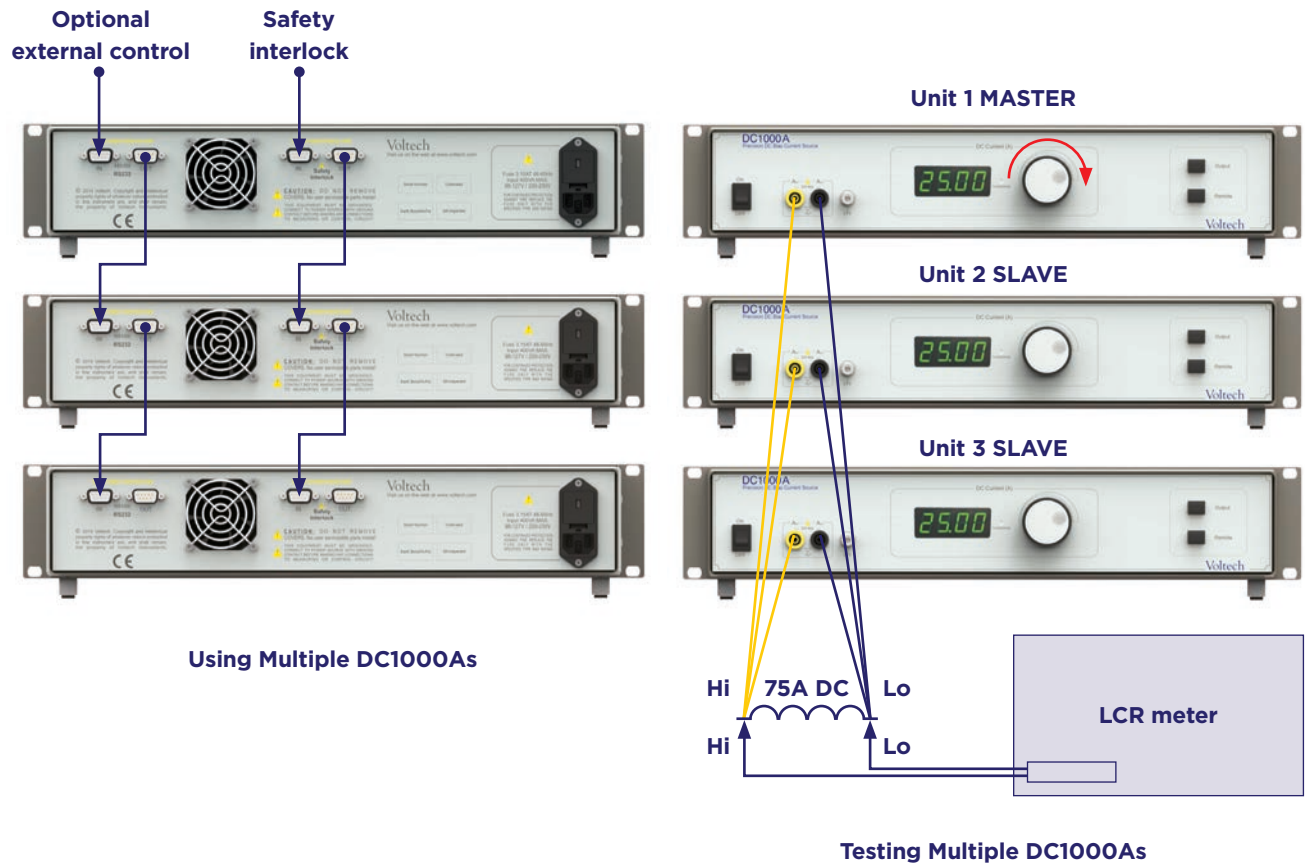



PATENTED TECHNOLOGY

Voltech's patented technology (shown in simplified form in Figure 1) dramatically reduces the errors encountered when a traditional DC current source and LCR meter are connected in parallel across the same unit under test (UUT), as is necessary in DC bias testing.

In any such practical arrangement, AC test current from the LCR meter is prone to stray into the output circuitry of the DC current source. This in turn creates an error in the resulting inductance measurement.

Voltech's solution reduces these AC error currents by a factor of 100, instantly producing more accurate results. Moreover, any residual error is constant and independent of the current supplied by the DC1000A: so it can easily be compensated out by traditional LCR methods.

The DC1000A's output stages include high-gain control loops with inductive feedback. These feedback circuits inject an AC signal across the output inductance so as to drive the AC voltage across it towards zero: the effective AC input impedance of the DC1000A, as seen by the LCR meter, is therefore very high.

As well as increasing measurement accuracy, this strategy is instrumental in allowing the DC1000A to be used with any LCR meter - it eliminates the need for special connections or knowledge of meter settings. Moreover, it enables the use of standard short and open compensation, allows easy parallel interconnection, and makes for a smaller, lighter unit overall.

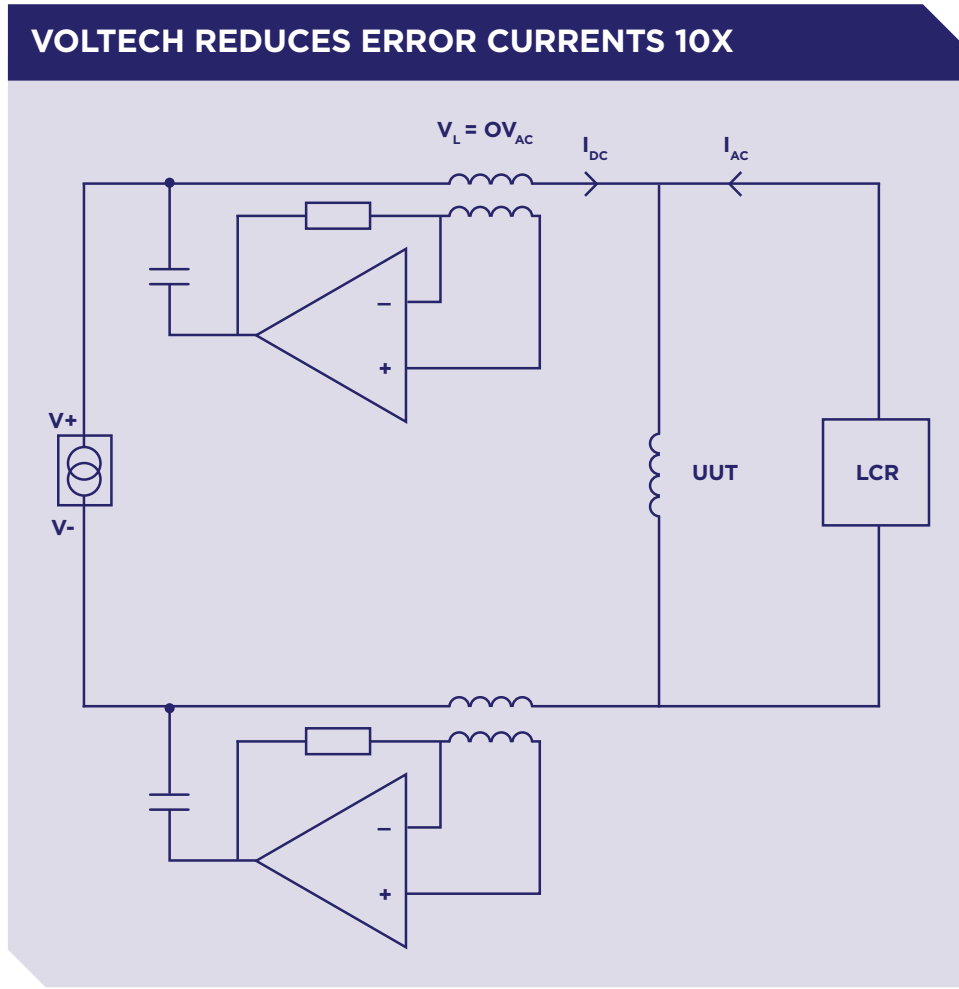

DC1000A specifications

Description		
DC Bias Current Output	Current Current when stacked	0 to 25A in 10mA steps. 500A with 20 x DC1000A
DC Bias Current Output	Accuracy of DC Current Compliance voltage Effect on the LCR measurement	±0.5% of reading ±25mA. 5V. Typically <10uA per Volt, see user manual for full error specification
Interfaces	RS232 Safety Interlock	Remote control Connection to operator safety system
Protection	Open circuit Over temperature Back -EMF (over voltage) Variable Speed Cooling Fan	warning shutdown and warning protects DC1000A and LCR meter

General, environmental
Line input IEC 3-pin socket 100-125V / 200-250V AC 48-65 Hz. 400 VA Max. Fuse 3.15A T
Dielectric strength 2.9 kV DC, power supply to case, for 1 minute
Operating temperature +5° to + 40°C
Humidity 10% to 80% RH non-condensing
Mechanical Suitable for bench or 19" rack mounting Height; 88 cm Width; 475 cm Depth; 255 cm Weight; 10 kg

DC1000A Error current (µA per V)

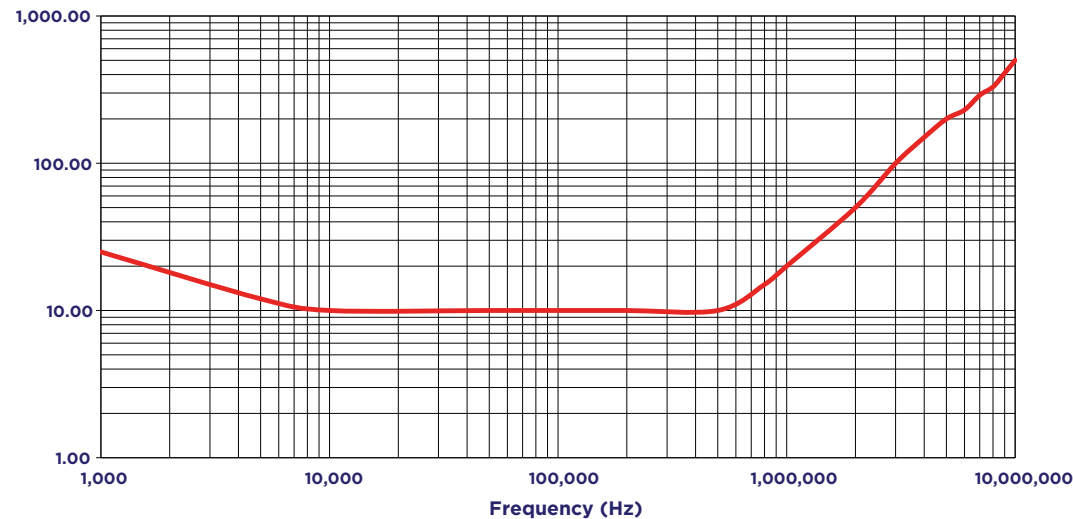

Whilst every care has been taken in compiling the information in this publication, Voltech cannot accept legal liability for any inaccuracies contained herein. Voltech has an intensive program of design and development that may alter product specification, and reserve the right to alter specification without notice and whenever necessary to ensure optimum performance from its product range.



www.voltech.com
E sales@voltech.com

Registered in England:
Reg # 2007598
© Voltech Instruments